



CITY OF MILPITAS Arts Commission and Parks, Recreation and Cultural Resources Commission

SPECIAL JOINT MEETING AGENDA

6:30 p.m.

Monday, January 6, 2025

Milpitas City Hall, Committee Conference Room, 455 E. Calaveras Blvd

1. Call to Order
2. Pledge of Allegiance
3. Roll Call
4. Seating of Alternates
5. Approval of Agenda: January 6, 2025
6. Approval of Subcommittee Meeting Minutes: November 13, 2024

7. Public Forum

Those interested are invited to address the Commission on any subject not on the agenda. Speakers may provide their name and city of residence for the record, and comments may be limited to three minutes, or less. As an item not listed on the agenda, no response is required of the Commission or staff. However, Commission members may request staff to add the item to a future meeting agenda. This public meeting will be led with professionalism, respect, and civility, so profanity and/or vulgar language will not be allowed.

8. Announcements

9. Business Items

a. Womanhood Marker Proposal for Delano Manongs

Background: Assistant Director McLane will present a request from Arts Build Community and Santa Clara County's Office of Women's Policy to include one of the County's Womanhood project art markers in Delano Manongs Park. The marker would honor Dr. Dawn Mabalon, poet, journalist, historian, and activist, best known for her work documenting the history of Filipino Americans, including that of the Delano Manongs.

Recommendation: Recommend to City Council for or against participating in Santa Clara County's Womanhood project, allowing installation of an art marker commemorating Dr. Dawn Mabalon in Delano Manongs Park.

b. Historic Park Markers Public Art Project

Background: Assistant Director McLane will present design selection rankings from the Park Markers Subcommittee, which unanimously recommended the marker design from Vickie Jo Sowell.

Recommendation: Recommend to City Council the Vickie Jo Sowell design for the historical park markers.

10. Adjournment

KNOW YOUR RIGHTS UNDER THE OPEN GOVERNMENT ORDINANCE

Government's duty is to serve the public, reaching its decisions in full view of the public. Commissions and other agencies of the City exist to conduct the people's business. This ordinance assures that deliberations are conducted before the people and the City operations are open to the people's review.

For more information on your rights under the Open Government Ordinance or to report a violation, contact the City Attorney's office at Milpitas City Hall, 455 E. Calaveras Blvd., Milpitas, CA 95035
e-mail: mmutalipassi@milpitas.gov / Phone: 408-586-3040

The Open Government Ordinance is codified in the Milpitas Municipal Code as Title I Chapter 310 and is available online at the City's website www.milpitas.gov by selecting "I Want to . . . View " link.

Materials related to an item on this agenda submitted to the Commission after initial distribution of the agenda packet are available for public inspection at the Recreation and Community Services office at the Milpitas Community Center, 457 E. Calaveras Blvd., Milpitas and on the City website. Commission agendas and related materials can be

viewed online: www.milpitas.gov/our-government/commission/arts/

APPLY TO SERVE ON A CITY COMMISSION

Commission application forms are available online at www.milpitas.gov or at Milpitas City Hall. Contact the City Clerk's office at 408-586-3003 for more information.

If you need assistance, per the Americans with Disabilities Act, for a City of Milpitas public meeting, please call Recreation and Community Services Community Engagement and Inclusion Administrator Tegan McLane at (408) 586-3212, or send an e-mail to tmclane@milpitas.gov prior to the meeting. You may request a larger font agenda or arrange for mobility assistance. For hearing assistance, headsets are available in the City Council Chambers for all meetings.



CITY OF MILPITAS

Park Markers Subcommittee Meeting

MEETING MINUTES

6:30 PM

Wednesday, November 13, 2024
BARBARA LEE SENIOR CENTER
40 N. CALAVERAS BLVD.
MILPITAS, CA 95035

CALL TO ORDER	Assistant Director McLane called the meeting to order at 6:33 p.m.
ROLL CALL	PRESENT: Committee members Ehardt, Gomez, Strauss, Umarani ABSENT: Committee member Ghose City Staff: Tegan McLane – Assistant Director Justin Yount – Senior Public Services Assistant
PLEDGE of ALLEGIANCE	Assistant Director McLane led the Pledge of Allegiance
ALTERNATE SEATING	N/A
APPROVAL OF AGENDA	Motion to approve the agenda for November 13, 2024. Motion/Second: Ehardt/Strauss Motion carried by a vote of AYES: All NOES: 0
APPROVAL OF MINUTES	Motion to approve the minutes for August 12, 2024 Motion/Second: Umarani/Gomez Motion carried by a vote of AYES: All NOES: 0
PUBLIC FORUM	None
ANNOUNCEMENTS	None
BUSINESS ITEMS	a. Review and rank finalists proposals – Recreation and Community Services Department Staff Assistant Director Tegan McLane presented design proposal narratives and maquettes of the kiosk-style marker from four finalist artists, Adrian Litman, Cheryl Derricotte, Vicki Jo Sewell, and Kaspari Dell Workshop. The commission reviewed all four designs and unanimously selected artist Vicki Jo Sewell’s design to move forward for recommendation to the Arts Commission and PRCRC. Staff requested a second design be selected as well to move forward for review. The Commission selected the design from Kaspari Dell workshop as the second option.

Motion to recommend the design from artist Vicki Jo Sewell as a unanimous first choice and second choice design by Kaspari Dell Workshop move forward to the Arts Commission and PRCRC for review.

Motion/Second: Strauss/Gomez

Motion carried by a vote of AYES: All NOES: 0

FUTURE AGENDA ITEMS None

ADJOURNMENT With there being no further business, the meeting was adjourned at 7:14 p.m.

AGENDA REPORT

Joint Meeting of the Arts Commission and Parks, Recreation and Cultural Resources Commission



DATE: January 6, 2025

TO: Honorable Chairs and Commissioners

FROM: Tegan McLane, Assistant Director, Recreation and Community Services Department

SUBJECT: Womanhood Marker Proposal for Delano Manongs **(Item 9A)**

Executive Summary:

Assistant Director McLane will present a request from Arts Build Community and Santa Clara County's Office of Women's Policy to include one of the County's Womanhood project art markers in Delano Manongs Park. The marker would honor Dr. Dawn Mabalon, poet, journalist, historian, and activist, best known for her work documenting the history of Filipino Americans, including that of the Delano Manongs.

Staff Recommendation:

Recommend to City Council for or against participating in Santa Clara County's Womanhood project, allowing installation of an art marker commemorating Dr. Dawn Mabalon in Delano Manongs Park.

Financial Impact:

Design and installation of the marker is funded by Santa Clara County Office of Women's Policy and sponsors of the project. Staff time to coordinate with the County is expected to be minimal. Maintenance of the sign is also expected to be very minimal.

Description:

The Santa Clara County Office of Women's Policy has funded a Countywide public art project that will install markers in public spaces around the County commemorating local women who have made important contributions in a number of fields. These markers are metal signs bearing an artist designed visual code that the public can scan with a phone application as they might a QR code to access artwork, poetry and storytelling about the women.

The project coordinators, Art Builds Community, have approached Milpitas requesting permission to place a marker Dr. Dawn Mabalon in Delano Manongs Park. Dr. Mabalon was a poet, journalist, historian, and activist. She was third generation Pinay, and the first Pinay to earn a Ph.D. in American History from Stanford University. Her academic research focus was Filipino American history, including work on the life of Larry Itliong and the Delano Manongs.

Attachments:

1. Santa Clara County Office of Women's Policy Proposal



WOMANHOOD

Journey Through Womanhood - 2024 Presentation



WOMANHOOD TEAM

ART BUILDS
COMMUNITY



OWP
Office of Women's Policy



Amanda Rawson

*Research Director, Project Manager,
Partner*



Quynh-Mai Nguyen

Creative Director, Partner



Barbara Goldstein

Public Art Management, Partner



Cassandra Staff

*Manager, County of Santa Clara
Office of Women's Policy*



OVERVIEW OF PROJECT TO DATE

PLANNING: Developed a framework for a long-term project

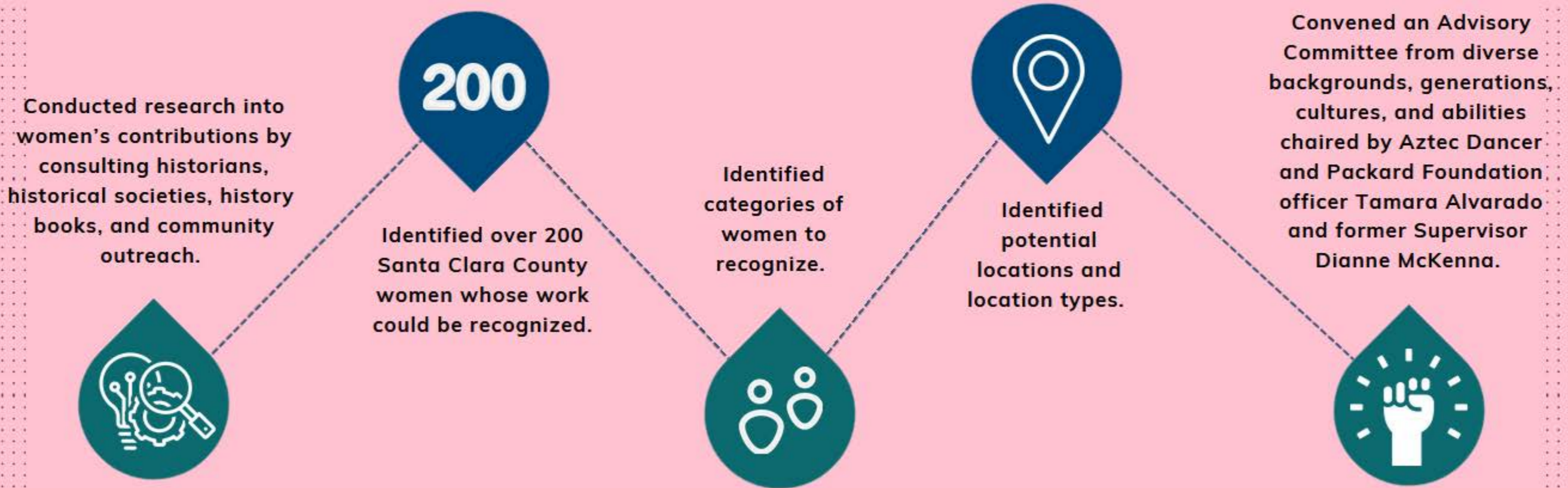

MARKETING CAMPAIGN:

Reached out to community members for ideas and feedback.



Launched social media for project via Facebook, Instagram, and Twitter



Published 20 online newsletters.



Conducted 22 focus groups and popup events.



Produced 14 online webinars explaining project and highlighting women artists honoring women.



- Received Abierto Grant to launch temporary projects in downtown San Jose employing 13 women artists who honored 20 women.
- Created videos of artists discussing each temporary project.
- Received Abierto Grant to create banners honoring immigrant women. These are currently installed on Alum Rock Avenue in East San Jose opposite the School of Arts and Culture.
- Honored as Community Leadership Marshalls for RWB Parade



WEBSITE:

Created two robust websites that inform and seek feedback about the project



Honored Women Database

- Individual pages of honored women including bio, facts, and public artwork
- Created as a resource for educators and students, later phases will include a curriculum.

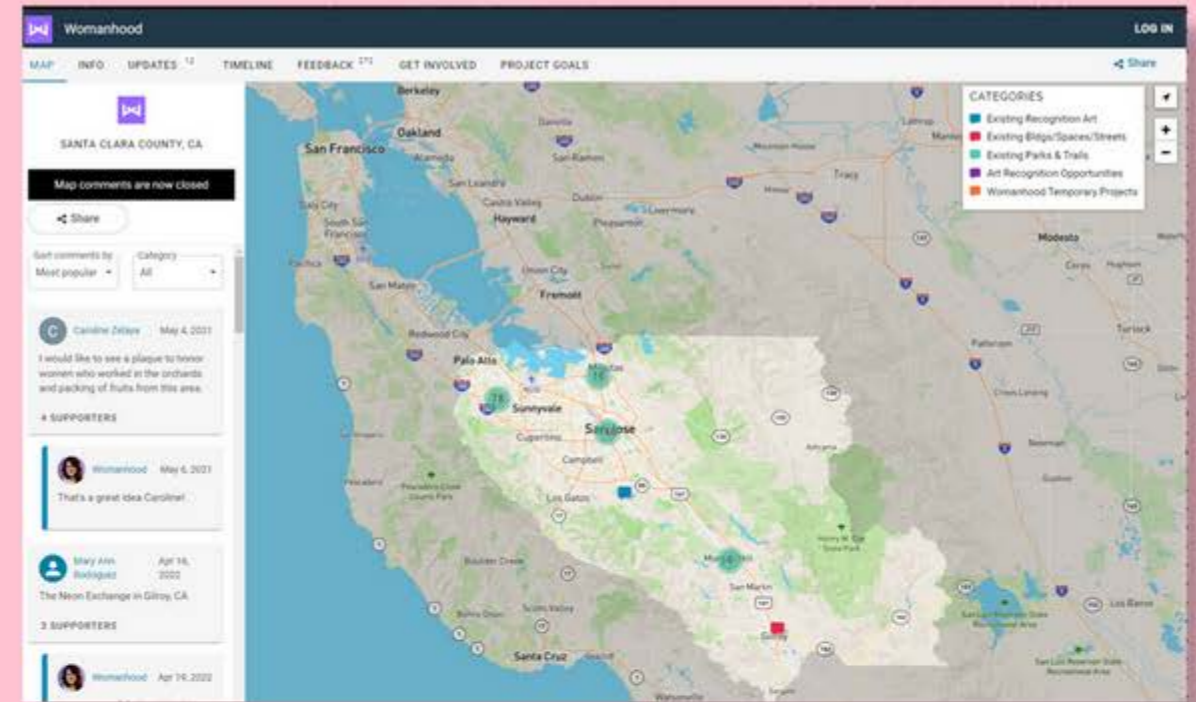

Community Engagement Site

- Mapping site allows people to pin their comments on a map of the County.
- 5 Phone numbers linked to each County District for people to text/leave a voicemail in English or another language to be translated as a pin on the online map.

D1 How and where would you like to see women recognized for their contributions in District 17?

1.669.298.0689

Text or Leave a Voicemail >>>>>

D1 covers Morgan Hill, Gilroy part of South San Jose, and some incorporated areas >>>>>

*All text/voice messages are anonymous.

coUrb.co/Womanhood
womanhoodproject.org

WOMANHOOD OWP



TEMPORARY PROJECTS

Based on our community engagement, we were able to pull out feedback and test them out as pilot projects.





ANONYMOUS NO MORE BANNERS SERIES: HISTORIC BUILDINGS

Downtown San Jose Artist Residency honoring women suffragists through window illustrations and projection.





ANONYMOUS NO MORE BANNERS SERIES: EMPTY STORE FRONTS

Downtown San Jose Artist Residency honoring women in the arts and culture. Artwork like the quilts pictured here were photographed and turned into vinyl wraps to be placed on empty storefront windows.





ANONYMOUS NO MORE BANNERS SERIES: WALKWAYS & PASEOS

Downtown San Jose Artist Residency honoring women within arts and culture. Currently exhibiting off The Alameda in downtown San Jose.



How do we honor groups and archetypes?



“SHE IS MORE” BANNER SERIES IN EAST SAN JOSE

Celebrating immigrant women in Santa Clara County | East Side San Jose Artist Residency

In another life,
we are the sisters we always wanted,
and the friends we dreamed of having.

from *En Otra Vida*, by Ruby Morales





WOMEN OF THE CANNERIES MINI DOC



Women of the Canneries: Anonymous No More



Watch later



Share



Watch on  YouTube

A pilot project created based on community engagement feedback. We commissioned a local filmmaker to work with History San Jose and their archives on Cannery Workers. A mini doc was created with collected stories and images that were told through voice actors.

Filmmaker:
Tricia Creason-Valencia



JOURNEY THROUGH WOMANHOOD: Exploring Women's Contributions Through Art, Storytelling, and Augmented Reality

100 Artist designed immersive markers that can be displayed in-person and online, mapping of existing locations named for women.

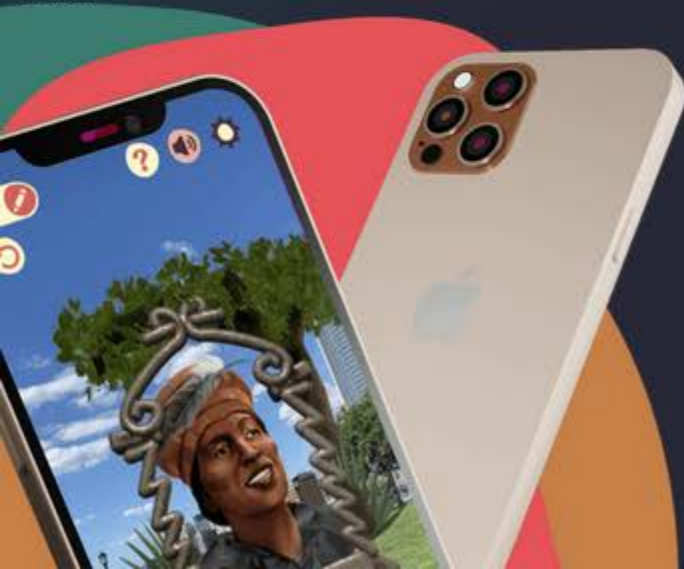

WOMANHOOD

Welcome Explorer!

Journey through Womanhood is a series of immersive and temporary public art monuments that explore the untold stories of women who have made significant contributions to the County of Santa Clara.

Through storytelling and augmented reality, explorers can locate these interactive markers placed at significant sites across the County to activate these portals into the past. We invite you to explore the accomplishments of these women and bring their stories to life.

In Honor Of:
Dr. Dawn Mabalon
Poet, Journalist, Historian, & Activist
1972 - 2018 | Palo Alto, CA

2024 ARTISTS
Arlene Biala
Jayann Bella
Frances Mendoza

WomanhoodProject.org

ART BUILDS COMMUNITY | OWP

Experience the Augmented Reality (AR)

Scan QR code to download the Kinfolk app.

1. Open the Kinfolk app.
2. Select the Scan mode.
3. Tap the green scan button.
4. Point your camera at the image above.
5. Your AR experience will begin.

** Make sure your phone is not silenced and volume is turned up.

Marker mock-up >>



MARKERS TO IDENTIFY PUBLIC ART PROJECTS AND TIE WOMEN'S CONTRIBUTION TO PLACE

Immersive:

- Artist Designed Augmented Reality (AR) Experiences
- Accessible w/ braille + audio
- Audio with artists describing artwork
- Curriculum to be developed in later phase in accessible online.

Size Options:

- 18"x12"
- 10"x12" smallest

Ex. mock-up of 10"x12" design (w/out braille):

WOMANHOOD

Welcome Explorer!

Journey through Womanhood is a series of immersive and temporary public art monuments that explore the untold stories of women who have made significant contributions to the County of Santa Clara.

In Honor Of:

Dr. Dawn Mabalon
Poet, Journalist, Historian, & Activist
1972 - 2018 | Palo Alto, CA

Experience the Augmented Reality (AR)

Scan QR code to download the Kinfolk app.

1. Open the KinFolk app.
2. Select the Scan mode.
3. Tap the green scan button.
4. Point your camera at the image above.
5. Your AR experience will begin.

** Make sure your phone is not silenced and volume is turned up.

2024 Artists:
Ariene Biala, Jayann Bellia, Frances Mendoza

Logos of partners

Project Artists

Honored Woman

Scan QR code to download Kinfolk App

Instructions to access the AR

.012" Aluminum
Facers with
Mirrored Surface

Solid Polyethylene Core

Dibond 3mm Benefits

- Rigid & Lightweight
- Weather & UV Resistant
- Recyclable
- Non-Corrosive
- Easily Cleaned
- Fire Proof

Maintenance

- Protective Coating
- Soap & Water Cleaning
- 2-3 x / year

Marker Duration

- minimum 5 years



Mock-up of marker to be installed directly on the wall of the Inez Jackson Library in San Jose, CA



Does your site have design guidelines for installation?



TIMELINE 2024 - 2025

December 2024

- Connect with committee members
- Secure marker locations for first 20
- Design marker mock up

February 2025

- Markers designed and fabricated
- Troubleshoot AR Projects
- Marker Installation
- Womanhood Project Campaign

January 2025

- Final design of markers
- Fabricate markers
- Start Womanhood Project Campaign

March 2025

- Continue Installation / Troubleshooting
- Womanhood Campaign
- Womanhood Unveiling Party - THU, March 20, 2025
- Programming/Tours

April 2025 +

- Continued Womanhood Programming



2
0
2
4

A
R
T
I
S
T
S

WOMEN IN TECH



Kiana Honarmand
interdisciplinary artist

WOMEN IN SOCIAL JUSTICE



Kathy Aoki
*multidisciplinary visual artist,
educator*

WOMEN IN SPORTS



Elba Raquel
*multidisciplinary artist,
educator*

WOMEN IN SPACE & SCIENCE



Pantea Karimi
*multidisciplinary artist,
researcher, and educator*

WOMEN IN THE ARTS



Jayann Bella
*visual artist, educator,
curator*



Frances Mendoza
*visual artist, interdisciplinary
performance artist*



Arlene Biala
*poet, interdisciplinary
performance artist*



HONORED WOMEN

Arts

- **Placita Todtod** - singer, entertainer, community activist
- **Iris Chang** - journalist, author, political activist
- **Dr. Dawn Mabalon** - poet, journalist, historian, activist
- **Ann Woo** - co-founded Chinese Performing Arts of America (CPAA)

Sports

- **1896 Stanford Women's Basket Ball Team** - introducing basketball to the west coast and into the Cal-Stanford rivalry
- **Cathy Jamison** - SCC's First Female Olympian - Swimming
- **Margaret Jenkins** - SCC's First Female Olympian - Discus
- **Sharon Chatman** - former SJSU basketball coach, lawyer, judge

Space & Science

- **Anne Estelle Glancy** - Astronomer, computer and lens designer
- **Edith Cummings** - Astronomer
- **Harriet Blanchard Mundy** - Environmentalist
- **Mary E Pulsifer Ames** - Botanist
- **Phoebe Waterman Haas** - Astronomer, made observations at Lick Observatory

Tech

- **Elizabeth J Feinler** - pioneering information scientist, former Director of the Network Information Systems Center
- **Joanna Hoffman** - original member of both the Apple Computer Macintosh team and the NeXT team.
- **Nomi Trapnell** - pioneer in software engineering and product management
- **Sandra Kurtzig** - businesswoman, tech entrepreneur

Social Justice & Community

- **Artemas Ginzton** - founder of Women's Regional Workshop for Parks and Trails
- **Asencion Solorsano** - medicine woman
- **Elinor Valley Cogswell** - news writer, editor in chief
- **Inez Jackson** - activist, teacher, postal worker



LOCATIONS FOR MARKERS

CONFIRMED

- Computer History Museum
- James Lick Observatory
- Museum of American Heritage

PENDING

- Santa Clara County Branch Libraries
- Stanford University
- San Jose State University
- Gilroy
- Delano Manong Park
- Iris Chang Park
- Japantown
- Alviso Marina County Park



ANN WOO





ARTEMAS GINZTON





NOMI TRAPNELL





ASCENCION SOLORSANO





HARRIET BLANCHARD MUNDY



Harriet Mundy Marsh in Palo Alto Baylands,
named after Harriet Mundy

Margaret Jenkins



Margaret Jenkins was Santa Clara County's first female Olympian. She competed in the discus at the 1928 and 1932 Summer Olympics, the first two Games to include women. In 1928, the javelin was not included in women's Olympic competition, but it was Jenkins' true talent: she set the world record in San Jose with a throw of 129 feet, 1 1/2 inches. Jenkins was also exceptionally accomplished in track, tennis and volleyball. Plus, she had her pilot's license, was a Naval officer in WAVES (Women Accepted for Volunteer Emergency Service) and became a founding member of the Santa Clara County Parks and Recreation Committee. A graduate of Santa Clara High and San Jose Teachers College, Jenkins taught in the Santa Clara school district for 31 years. Jenkins was inducted posthumously into the San Jose Sports Hall of Fame in 2008. Additionally, Jenkins practiced fly fishing and did so into retirement in her Lake Tahoe home.



MARGARET JENKINS



IRIS CHANG





SUPPORT

Can a marker be installed at your location?

- Confirm locations by December 31st
- Fabricate markers in January 2025
- Install markers in February - Early March 2025
- Unveil in March 2025 during Women's History Month

Benefits to hosting a marker:

- Being a part of a County-wide women's recognition public art project.
- Celebrating this woman's contribution to the County at your location.
- Activating your space with immersive public art.
- Low-impact installation.
- Potential opportunity for programming with the artist (ex. artist talks, tours, etc)
- Collaborative Marketing Campaign
- Presence online in the Womanhood and AR App.

For more information:

- Contact:
 - Amanda Rawson, amanda@artbuildscommunity.com
 - Quynh-Mai Nguyen, quynh-mai@artbuildscommunity.com
- Website:
 - www.womanhoodproject.org
 - www.artbuildscommunity.com

Design Proposal Narrative
Milpitas Historical Park Markers

“Natives”

Vickie Jo Sowell, Sculptor

<http://unrulyimages.com>

510-459-9026

Artist Statement

The Milpitas Historical Park Marker project offers the City an opportunity to establish a consistent identity for its parks across all locations. For this project I've chosen the theme of "Natives," using imagery drawn from the flora and fauna native to the Milpitas region, live oak and sycamore leaves, as well as critical pollinator species, the bees, monarch butterfly, and Anna's hummingbird. These will be rendered as multiple machine-driven cutouts in steel. As the drawings and renderings on the following pages show, the cutout panels will be joined to form a structurally strong zig-zag shaped kiosk, secured to ground-level concrete pads. On two of the three sections of the kiosk, space is provided for back-to-back waterproof outdoor display cases. The maquette I've provided illustrates two options, one in which two display cases are mounted side by side, the other where they are separate.

Proposed Materials and Dimensions

Each kiosk will be constructed of three 72" x 35" rectangular frames built from 2.5" square steel tubing, hinged at approximately 120 degree angles to each other. Within these structural frames, thematic art panels waterjet cut from 1/4" Sheet Steel are welded, one the full height, and the other two panels half high, 36" x 35", providing space on front and back to mount four off-the-shelf Swansea Outdoor Lockable Display Cases. At the bottom of each rectangular frame the square tube will extend two legs 8" long, terminating in steel mounting plates that will be bolted to a concrete pad. For sections in which display cases are inset, overhanging roof elements will be added, to provide additional protection for the waterproof, lockable cases.

The use of computer-driven water-jet cutting allows replacement of any severely damaged panels, as well as for easy scaling of the images for other applications in other signage in the parks, if desired. Their angled arrangement can be adjusted to fit larger and smaller park locations. The suggested golden tan color RA1007 is just one of many choices available from Prismatic Powders, see the attached sample sheet. The commercially available Swansea outdoor display cases I propose can be easily replaced if damaged.

Because the seven kiosks will be constructed of interchangeable, reproducible parts, the longevity of the kiosks is indefinite. Many of the similar powder-baked surfaces I've installed have been in place for over twenty years. The cutout artwork panels are unattractive to graffiti placement, but the budget includes matching spray paint for touch-up if this should prove necessary.

Timeline

Following Contract Award, a 50% materials advance (\$50,000) must be available to begin work.

CAD design 4 weeks from award

Stephen Bailey

Waterjet cutting 4 weeks total, 8 weeks from award

Shane's Watercutting

Assembly of panels, 4 weeks total, 12 weeks from award

Artist Vickie Jo Sowell and Assistant Keith Harker at artist studio in Emeryville

Powder-baking panels and structure, 4 weeks total, 16 weeks from award

Melrose Powder-baking

Test assembly, 2 weeks, 18 weeks from award

Transportation and Delivery, 2 weeks, 20 weeks from award

Artist Vickie Jo Sowell and Assistant Keith Harker

Installation, 2 weeks, 22 weeks from award

Project Budget

Artist Fee	24,000
Studio Assistant	
Welding	7,000
Shop Fee	3,000
Contractor services	
CAD	6,000
WaterJet cutting	18,000
Powder-baking	14,000
Materials and supplies	
Steel stock	1,500
Display Cabinets (28)	5,500
Spray Paint for Maintenance	1,000
Transportation	
Between vendors	1,000
To Milpitas Park sites	2,000
Field coordination (site visit)	4,000
Insurance and Permits	3,000
Installation*	<u>10,000</u>
TOTAL	\$100,000

*Prefer fresh concrete pads with embedded bolts, for which I'll supply template. Otherwise, securing bolts will be drilled into existing concrete.

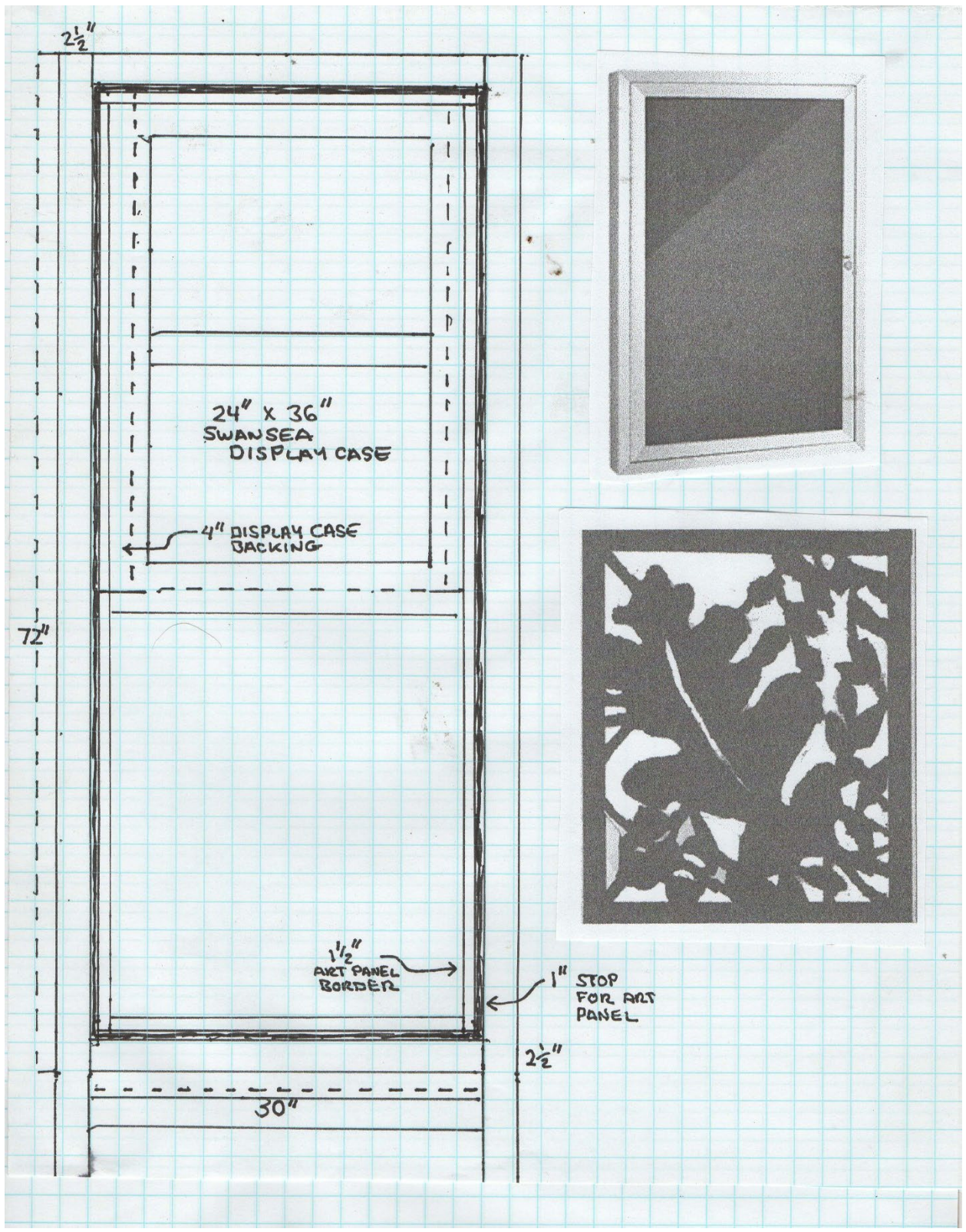

Kiosk Panel and Display Cabinet, structural detail



Kiosk Design 1



Kiosk Design 2



Kiosk Design 3

Kiosk Maquettes (Physical items available if desired)



Configuration A



Configuration B



Configuration C





www.PRISMATICPOWDERS.COM | 1-866-774-7628

ENDLESS APPLICATIONS

GET THE LATEST NEWS, UPDATES, VIDEOS, OFFERS, & MORE

JOIN US AT PRISMATICPOWDERS.COM TO:

- BROWSE OVER 6500 POWDER COATING COLORS
- VIEW THOUSANDS OF GALLERY IMAGES
- SEE HOW-TO & PRODUCT VIDEOS
- FIND ONLINE SPECIALS & DISCOUNTS

6500 POWDER COATING COLORS

PRISMATIC POWDERS

PRISMATIC POWDERS RAL COLOR CHART

PRISMATIC POWDERS OFFERS THE WORLD'S LARGEST SELECTION OF CUSTOM COLORED POWDER COATINGS.

www.PRISMATICPOWDERS.COM | 1-866-774-7628

Prismatic Powders Color Sample Chart

2-1/2" SQ {A} x 2.334" ID {B} x .083" Wall {C} Square Steel Tubing

 [E-mail this product to a friend](#)

[Click here for material description, specification sheets and typical uses.](#)

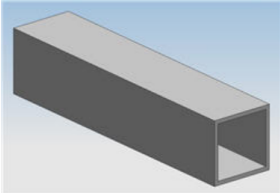

 Show Larger

Click [here](#) for important information about telescoping.

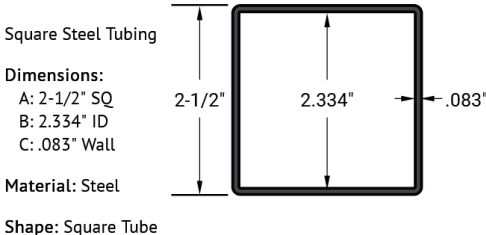



Sample installation at Jose Higuera Adobe Park

Historical Park Markers, City of Milpitas -Artist's Statement:

Parks are recognized as powerful tools for urban communities and local economies.”
-City Parks Alliance

Parks are an ideal place for movement, providing the room and resources needed for running, walking, playing games and sports, and other active pursuits.

In addition to preserving the natural environment in highly populated areas, urban parks are also essential for maintaining, and in many cases embodying, the cultural and historical significance of a city. Whether they're home to museums that help preserve a city's history or the land itself holds historical value, urban parks can be a great way to keep key historical figures, events, and eras in the memory of today's residents.

- Earth Share

While the key functions of city parks are numerous, two functions are often highlighted - the maintenance of physical health and the preservation of cultural or historical heritage.



Parks offer spaces suited to both vigorous activity and solitary contemplation. Parks become places for physical exploration as people move through the space to find the area specific to their needs.

In keeping with this movement, Kaspari-Dell Workshop proposes to design and build seven information kiosks that reflect the dynamism of city parks as it applies to health and heritage. We're using the market or street vendor cart as a jumping off point to create kiosks that will be playful and resist being viewed as static, fixed objects.

While the market cart carries an obvious nod to Milpitas' history as an agricultural center, it also refers to activities like fairs and farmer's markets that often occur in parks and other similar public spaces. The cart moves from one place to another often following its public. Our cart suggests human scaled mobility - the movement and activity of a park. It will appear as if the kiosk can travel throughout the park to disseminate its information. This implied mobility allows for the kiosk to be placed almost anyplace in the park - similar to a stroller or bicycle.

The panels of the cart are arranged in an accordion-like fashion suggesting movement like that of unfolding a pamphlet or the opening of a folding door. The planes of the piece appear to be hinged or able to pivot with and against each other, implying additional movement and variability. They also offer opportunities for color and shadow effects which will change throughout the day.

As stated by the call, the panels will provide cultural and historical information pertinent to each individual park. We have kept the structure relatively simple and unadorned so as to avoid competing with the information and images presented on the didactic panels.

General Specifications:

- Proposed dimensions - 74" (L) x 74" (H) x 25.5" (D). NOTE: Structure is dimensioned to accommodate portrait formatted signage, but can be easily re-worked if landscape or other formats are preferred.
- Proposed materials - Welded steel tubing, laser cut steel parts and panels, and full color printed aluminum didactic panels. Continuous welds throughout. The steel components will be painted with a two part catalyzing paint system and VandlTop anti-graffiti coating. (Final colors T.B.D. in discussions with City representatives.) Stainless steel fasteners will be provided throughout (security type as required). Didactic panels to be digitally printed on aluminum with UV resistant coating applied by the print vendor.
- Proposed artist and studio assistant - Irve Dell, Brad Kaspari, and one studio assistant to be hired for this project.
- Proposed foundry or fabrication firm - Kaspari Dell Workshop studio in Saint Paul MN.
- Recommended installation procedure, including any special equipment required - The structures are designed to be assembled on site to aid with shipping and handling. We would do the installation ourselves. Typically we use $\frac{3}{8}$ " or $\frac{1}{2}$ " threaded rod set in Hilti (or equivalent) concrete epoxy when setting in footings or paved surfaces. However we would expect to discuss this with City staff so as to adhere to the City's prevailing installation standards (if any). We would also rent a truck to transport each structure to its Park site.
- Expected lifespan of the kiosk - Based on past work and the fabrication systems we employ we'd expect a minimum 20 year lifespan under normal usage.
- Recommended print method and materials for interpretive panels - UV Digital Printing on aluminum substrate. Additional UV resistant coating applied by the print vendor at time of printing.
- Expected lifespan of the panels - Five year minimum guarantee provided by Archetype Design printers - nationally known signage company based in Bloomington, MN. <https://archetypedesign.com>
- Recommended annual and sporadic maintenance necessary to achieve the expected lifespan of kiosk and panels - No annual maintenance required. Periodic washing with mild detergent every few years will help with longevity, but is optional. Note that this would necessitate re-application of the sacrificial graffiti coating.
- How/if the public is encouraged to interact with the artwork - It's expected the public will stand near the kiosk to read and view the didactic panels composed by the city. It's also expected the kiosk can be a landmark that will allow for photo opportunities and act as a meeting point.
- How/if the public is prohibited from interacting with the artwork, including safety measures - The public is to be prohibited from standing on, attempting to move, or climbing on the kiosk
- Timeline - Timeline to be coordinated with the City. Our expectations would be to have final design approval by Fall 2024, full drawing set and beginning of fabrication by Winter 2025, fabrication completion by early Spring 2025, and installation by late Spring or early summer 2025.



Milpitas Historical Park Markers - Kiosk Front View



Milpitas Historical Park Markers - Kiosk Side View

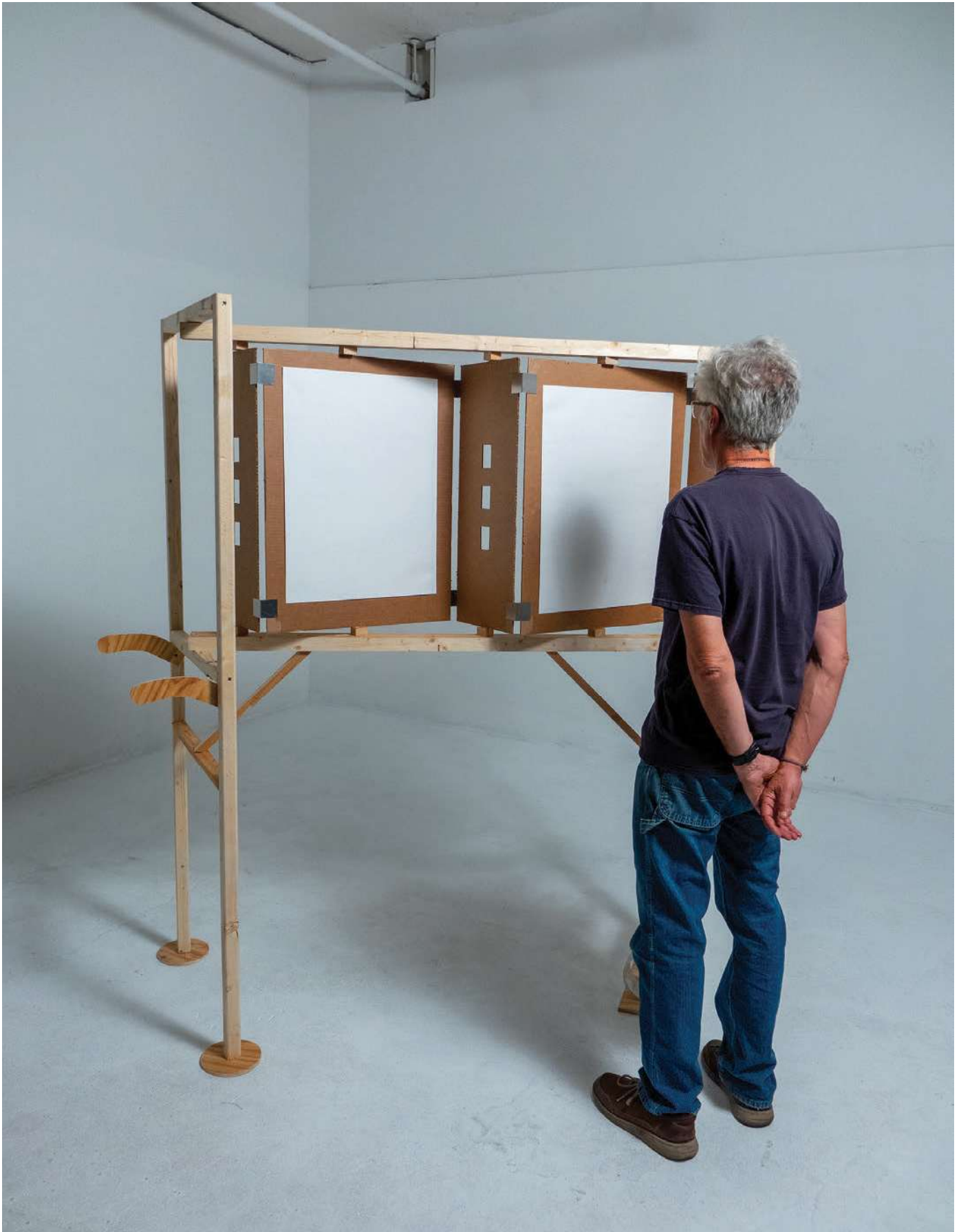

Milpitas Historical Park Markers - Kiosk Back View

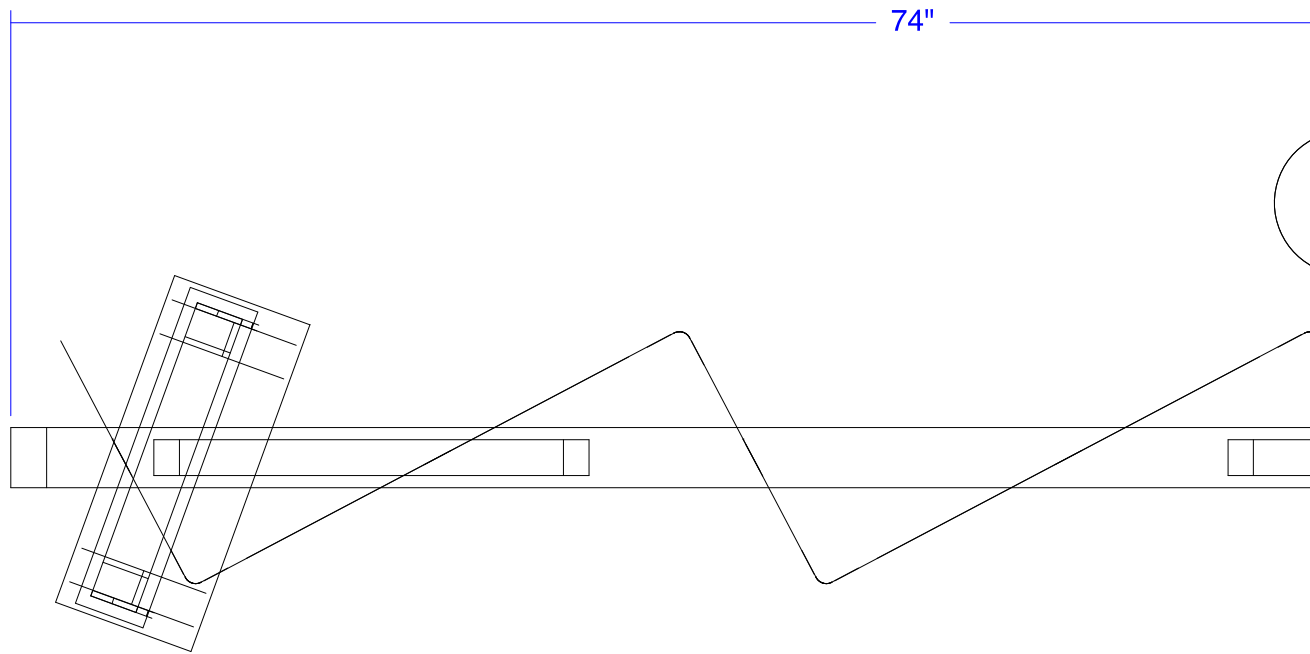

TOP VIEW
1-1/2" = 1'

MILPITAS HISTORICAL PARK MARKERS
WORKING WIREFRAME VIEWS
9/25/24

GENERAL NOTES:

1. All structural elements to be from welded mild steel. All welds to be continuous.
2. All steel to be coated with Sherwin-Williams 2-part catalyzing paint and V.
3. Final colors T.B.D. in discussion with City representatives.
3. All connecting hardware to be stainless steel and security type as required.
4. Didactic panels to be digitally printed on aluminum and bolted to backing.
5. Installation hardware T.B.D. in discussion with Milpitas City staff.

Milpitas Public Art - Working Budget				
Budget Total				\$100,000
DESCRIPTION	Cost Each	# Req	Ext.	Totals
Design Fee				\$10,000
CADD Plan Sets for Additional Kiosk Fab				\$3,000.00
Additional CADD for cutting & templates				\$1,200.00
Misc. Administration & Overhead				\$2,500.00
Travel				\$4,000
Site Visits & City/Community Meetings	\$1,500.00		\$1,500.00	
Installation	\$3,500.00		\$3,500.00	
Sub Total				\$5,000
Expendable Materials & Subs				
Didactic Panels (18" x 24")	\$300.00	28	\$8,400.00	
Steel	\$4,000.00		\$4,000.00	
Laser cutting	\$2,500.00		\$2,500.00	
Formed angle	\$300.00		\$300.00	
Misc. S.S. Hardware	\$1,000.00		\$1,000.00	
Sandblasting & Painting	\$6,000.00		\$6,000.00	
Parts Deburring	\$300.00		\$300.00	
	\$0.00		\$0.00	
	\$0.00		\$0.00	
	\$0.00		\$0.00	
Sub Total				\$22,500
Fabrication				
Studio Assistant	\$5,000.00		\$5,000.00	
Cutting	\$2,125.00		\$2,125.00	
Milling	\$1,500.00		\$1,500.00	
Jigging	\$750.00		\$750.00	
Misc. Expendable Materials	\$1,000.00		\$1,000.00	
Welding	\$3,000.00		\$3,000.00	
Chasing	\$1,500.00			
Sub Total				\$13,375
Installation				
Crating	\$1,500.00		\$1,500.00	
Shipping to Site	\$4,000.00		\$4,000.00	
Final Assembly	\$3,500.00		\$3,500.00	
Installation Hardware	\$1,000.00		\$1,000.00	
Equipment rental	\$750.00		\$750.00	
Installation Oversight (per day)	\$1,200.00	7	\$8,400.00	
Documentation	\$3,000.00		\$3,000.00	
Insurance	\$1,200.00		\$1,200.00	
Studio Rent	\$1,100.00	4	\$4,400.00	
Sub Total				\$27,750
TOTAL BEFORE CONTINGENCY				\$89,325
CONTINGENCY			11.95%	\$10,674
GRAND TOTAL				\$99,999





KDW-Milpitas Submission

Final Audit Report

2024-10-01

Created:	2024-10-01
By:	Bradley Kaspari (BKASPARI@KASPARIDESIGN.COM)
Status:	Signed
Transaction ID:	CBJCHBCAABAAfDrz0QaXJ30mIXSiuncAYnrXerREL800

"KDW-Milpitas Submission" History

-  Document created by Bradley Kaspari (BKASPARI@KASPARIDESIGN.COM)
2024-10-01 - 5:05:03 PM GMT
-  Document emailed to Irve Dell (irve@kasparidell.com) for signature
2024-10-01 - 5:05:15 PM GMT
-  Email viewed by Irve Dell (irve@kasparidell.com)
2024-10-01 - 5:05:38 PM GMT
-  Document e-signed by Irve Dell (irve@kasparidell.com)
Signature Date: 2024-10-01 - 5:06:05 PM GMT - Time Source: server
-  Agreement completed.
2024-10-01 - 5:06:05 PM GMT